

# **PERRIN**

## **STI 25mm Rear Sway bar Kit**

09282010

**Thank you for purchasing the PERRIN Sway Bar Kit Upgrade. Persons experienced in the installation and proper operation of suspension systems should only perform installation. Please read through all the instructions before performing the installation.**

**SPECIAL NOTES ABOUT THIS PRODUCT:** Many modifications (and combinations of modifications) are not recommended and may NOT be permitted in your country, state or other form of local government. Consult your owner's manual, instructions for each product and all laws before undertaking these modifications. The owner and user are solely responsible for the legality and safety of the vehicle you modify using these components! ALTA and PERRIN Performance are not responsible for any physical or financial damages as result of proper or improper installation, usage or ownership of this product.

Use of this suspension product will result in a change in the handling characteristics of your vehicle. As with ANY vehicle, extreme care must be taken to prevent loss of control or roll-over during all driving maneuvers. Always wear seat belts, and drive safely, recognizing that reduced speeds and specialized driving techniques may be required. Failure to drive this vehicle safely may result in serious injury or death! Once installed do NOT drive the vehicle unless you are familiar with its unique handling characteristic and confident in your ability to maintain control under all driving conditions.

Questions? Please contact us prior to proceeding with installation or use. Contact information is located on this page.

### ***SPECIAL NOTES:***

- The use of a factory service manual is highly recommended. These can be purchased or downloaded online at <http://techinfo.subaru.com>.
- <http://subaru.spx.com> is a place to buy OEM tools.
- It is critical that all bolts and nuts are tightened, improper tightening can cause serious injury or death.
- The use of a penetrating oil will greatly reduce the chances of galling threads on bolts as they are removed.
- We highly recommend the use of anti-seize on treads of all bolts, when reassembling.

### ***Parts Included with the PERRIN Rear Sway bar Kit:***

- (1) Rear 25mm STI Sway bar with 2 holes
- (1) Set of Stout Mounts
- (1) 25mm(9.5179) bushing Set
- (4) M8x40mm Grade 8 Hex bolts
- (4) M8 Washers
- (4) 3/8-24x1" Grade 8 Hex bolts
- (4) 3/8 grade 8 nuts

Checked By \_\_\_\_\_

### ***Install PERRIN Swaybar/Drop Down Brackets***

1. Park car on a smooth level surface. Using suitable commercial vehicle hoist or floor jack, raise vehicle onto jack stands. NEVER WORK UNDER A VEHICLE SOLELY SUPPORTED BY A JACK! DEATH OR INJURY MAY OCCUR.
2. Disconnect endlinks from existing sway bar. Depending on endlinks installed, this step can vary.
3. Remove stock sway bar from factory Drop Down Brackets, by removing (2) 12mm bolts, and (2) 12mm nuts.
4. Remove factory drop down brackets from chassis by removing (4) 12mm bolts.
5. Install PERRIN Sway Bar Mounts as shown. See Fig. 1 for correct Sway Bar Mount alignment. Failure to install correctly will result in improper alignment of sway bar bushings! Tighten supplied M8 bolts to 20ft-lbs.
6. Generously grease bushings using supplied grease and place them on new PERRIN bar. Align bushings and bushing brackets on sway bar, with dropdown brackets prior to installing. Install sway bar on PERRIN Sway Bar Mounts using the supplied bolts/washers. Tighten bolts to 30ft-lbs.
7. There is some adjustment front to back on the bushings, which can aid in different endlink, swaybar, and muffler combinations clearing one another. This should be adjusted after car is lowered to ground to check for clearance issues.
8. Connect end links using stock hardware removed previously. Tighten nuts to 40ft-lbs.
9. Lower car from stands and road test vehicle. If "squeaking" is noted in rear of car, re-grease bushings.

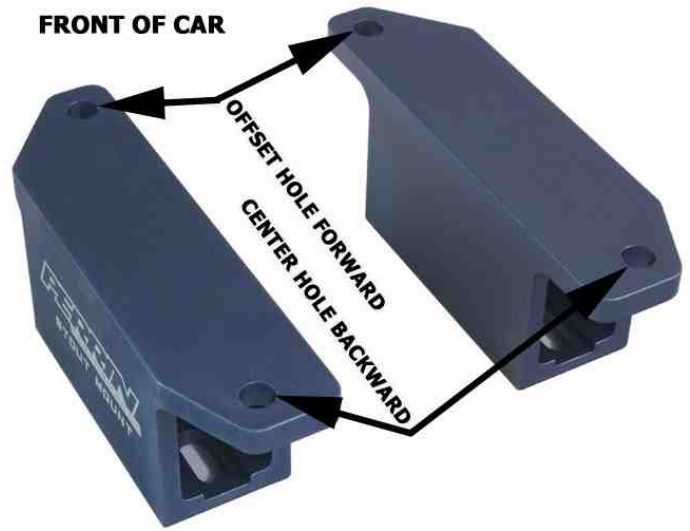
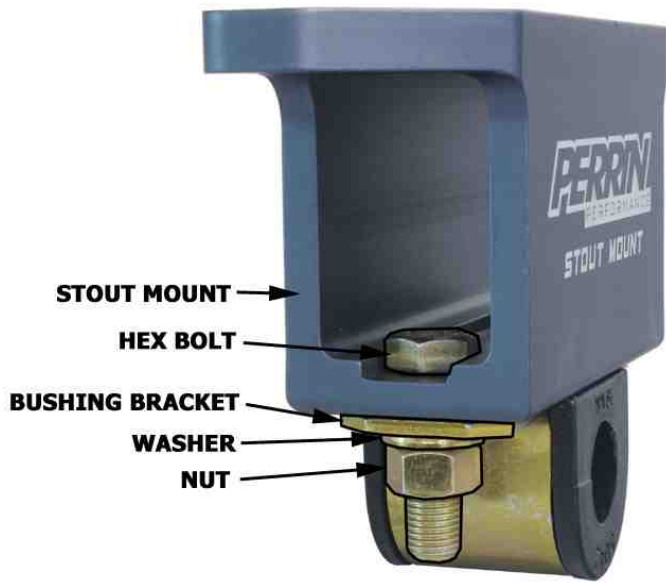

NOTE: STIFFER SETTINGS WILL INCREASE VEHICLES TENDENCY TO OVER STEER. SOFTER SETTINGS WILL INCREASE VEHICLES TENDENCY TO UNDER STEER. THE HANDLING OF YOUR VEHICLE WILL BE AFFECTED DRAMATICALLY WITH THE INSTALLATION OF THIS SWAY BAR AND THE END LINK POSITION YOU CHOOSE. DRIVE VEHICLE CAUTIOUSLY UNTIL YOU BECOME FAMILIAR AND ACCUSTOMED TO THE NEW HANDLING CHARACTERISTICS OF YOUR VEHICLE!



*Complete sway bar, Stout Mount, and Endlinks installed.*

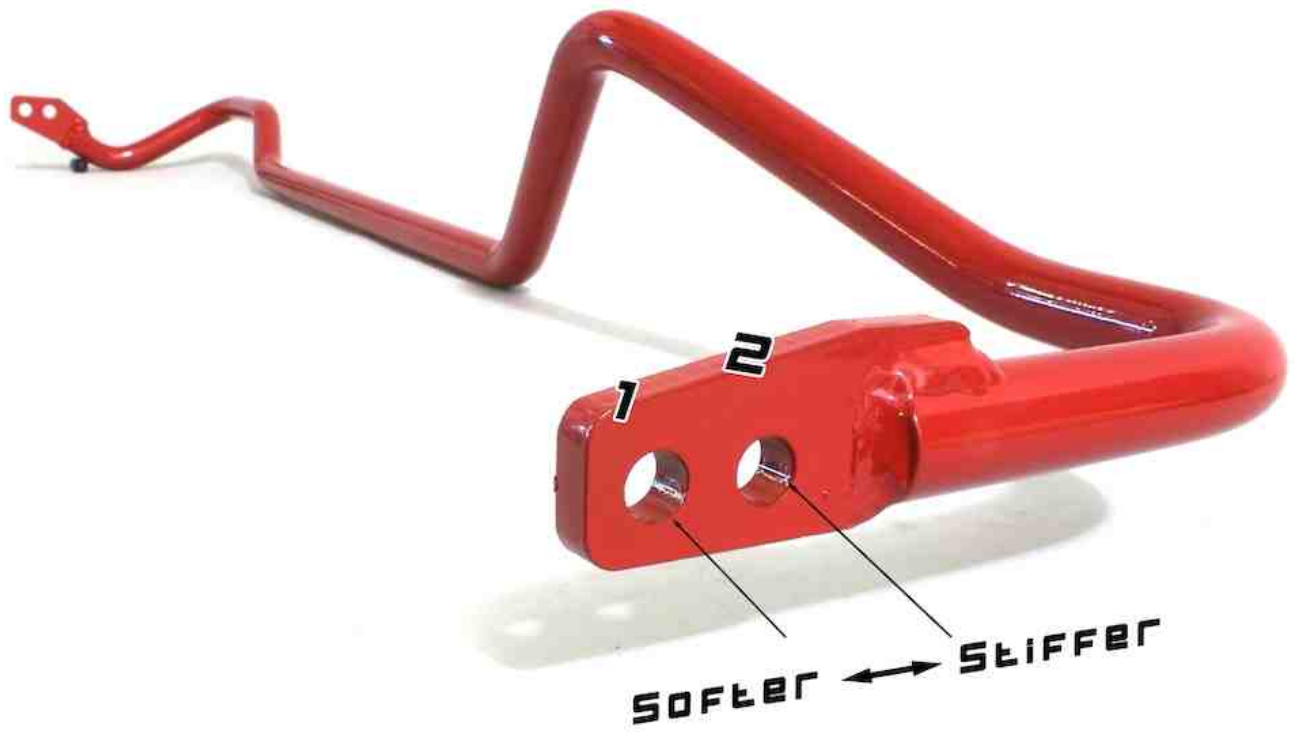

**Percentage Increase in stiffness over OEM 22mm bar**

	<b>Setting #1</b>	<b>Setting #2</b>	<b>Setting #3</b>
<b>PERRIN 25mm</b>	496%	617%	788%
<b>PERRIN 22mm</b>	290%	362%	461%

**For questions & comments please contact**

**[Tech@PERRINperformance.com](mailto:Tech@PERRINperformance.com)**

**503-693-1702**

**AIM contact ALTAPERRINSALES**